

# RF DETECTOR

## Critical Measurement for your Microwave Application



The RF detector monitors the irradiator for RF leaks. This device shuts down the system if excess microwave energy is released to protect the equipment from damage caused by faulty assembly, torn screens failing RF seals, or damaged shielding. The RF detector automatically tests the components of the detector circuitry at system startup, or when the test button is activated by the operator.

One RF detection device (part no. A018-001) must be installed for each light shield using the bracket supplied. The RF antenna (cone shaped protrusion) should point toward the potential source of RF (the irradiator screen). However, to protect the antenna from heat and UV light, it should be placed outside the light shield. It may "look" into the light shield through an existing opening or one made for this purpose. The tip of the sensing cone should be at least two inches from the opening into the light shield.

The RF detector should be installed 0.3m to 0.6m away from the lightshield, and generally between the lightshields and any area where personnel are working. Single or dual irradiator systems must have at least one RF detector. Multiple irradiator systems run as a single row (Master-Slave), should have (N-1) RF detectors, where N is the number of irradiators. If the system is configured as all Masters, an RF detector will be required for each irradiator.

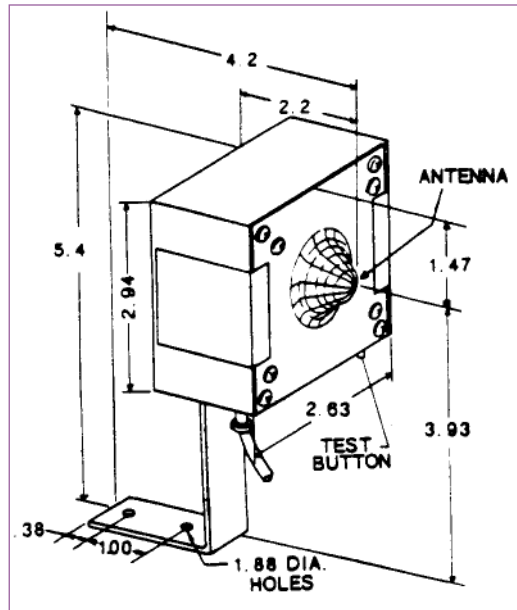
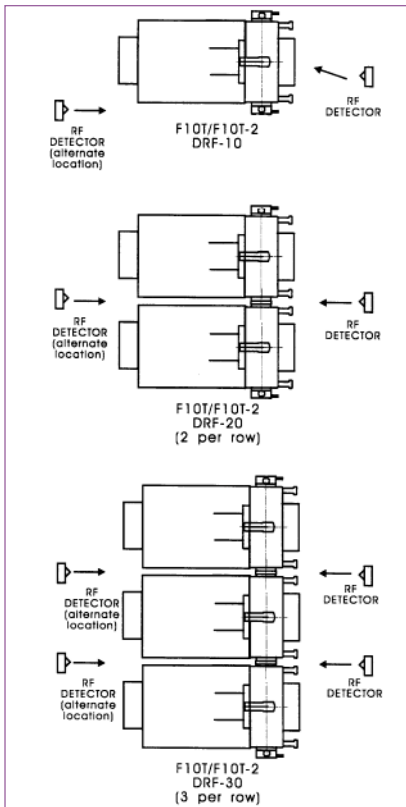

In order to ensure this component fits into your existing system, the RF detector's measurements are as shown.

The presence of metal surfaces near the detector may cause false readings; allow maximum open area around the device.

Item No.	Description
A018-001	RF Detector Kit
A018-003	Recalibration

### 24-HOUR PRODUCT SERVICES

Internet: [www.uvprocess.com](http://www.uvprocess.com)

E-mail: [info@uvps.com](mailto:info@uvps.com)



**UVPS®**  
UV PROCESS SUPPLY, INC.