



# **CURESPOT HO**

# **CURING SYSTEM**

---

## **OPERATING INSTRUCTIONS**

---

**U.V. PROCESS SUPPLY, INC.**  
**1229 W. CORTLAND**  
**CHICAGO, IL 60614-4805**

**Voice 773-248-0099 • 800-621-1296**  
**Fax 773-880-6647 • 800-99FAXUV**

COPYRIGHT © 2002 U.V. PROCESS SUPPLY, INC. ALL RIGHTS RESERVED



# I.

## GENERAL DESCRIPTION

The Cure Spot HO is a high intensity UV curing system that rapidly cures small areas of UV curable adhesives and coatings. The UV energy generated by the system can be directed at the UV curable material by a flexible liquid lightguide. UV exposure time is controlled by a shutter which is activated by the footswitch. Curing time is minimized by locating the end of the lightguide as close to the UV curable material as possible, but no less than 1/4" away.

## **II.**

### UNPACKING AND INSPECTION

Unpack the system and inspect it for shipping damage. Report damages, if any, to freight carrier. Save packaging for safe storage or future shipping.

## **III.**

### INSTALLATION AND OPERATION

The Cure Spot HO will arrive almost fully assembled. All that is required is to plug in the lightguide, power cord and footswitch. The system should be positioned in a dry location which does not obstruct airflow from the rear of the unit.

**IMPORTANT:** To insure proper output of the system is obtained, be sure to completely insert the lightguide into the mount prior to tightening the set screw. Be sure to lightly tighten the set screw to insure the lightguide remains in place during use.

To energize system, turn power switch to "on" position. Be sure UV spectacles are being worn. Wait 2-3 minutes for lamp to come to full power. The system is now ready to use.

The shutter operation of "manual" or "timed" mode can be selected by the rocker switch on the front panel. With the selector switch on "manual" the shutter will remain open as long as the footswitch is depressed. With the selector switch on "timed" the shutter will remain open for the preset time upon activation by the footswitch. The timer can be preset for 00.1 seconds to 99.9 seconds. The timer is pre programmed to function in the above fashion, other programs can be preset at the factory, contact ADAC for other program functions.

Position lightguide end no closer than 1/4" from material being cured. Locating lightguide end too close can cause lightguide end to become cloudy from vapors coming off curing material. This cloudiness can reduce UV output by as much as 50%.

Lamp life will be greatly enhanced if lamp cycling is kept to a minimum, leave lamp "on" through breaks. The hourmeter will record lamp on time. Reset hourmeter by inserting a small screwdriver into hole labeled "reset" and depressing switch inside.

**NEVER LOOK DIRECTLY AT LIGHT EXITING LIGHTGUIDE.**

## LAMP REFLECTOR REPLACEMENT

- Unplug system
- Allow lamp to cool 5 minutes or more
- Remove (4) thumbscrews which retain cover and lift off cover
- Unplug lamp lead wires
- Loosen (2) thumbscrews which hold upper Teflon bar 1/2 turn each
- Lift Teflon bar to 45 degrees
- Remove lamp-reflector assembly
- Reverse procedure above to install lamp-reflector assembly, be sure to align notch on reflector rim with tab on mounting plate

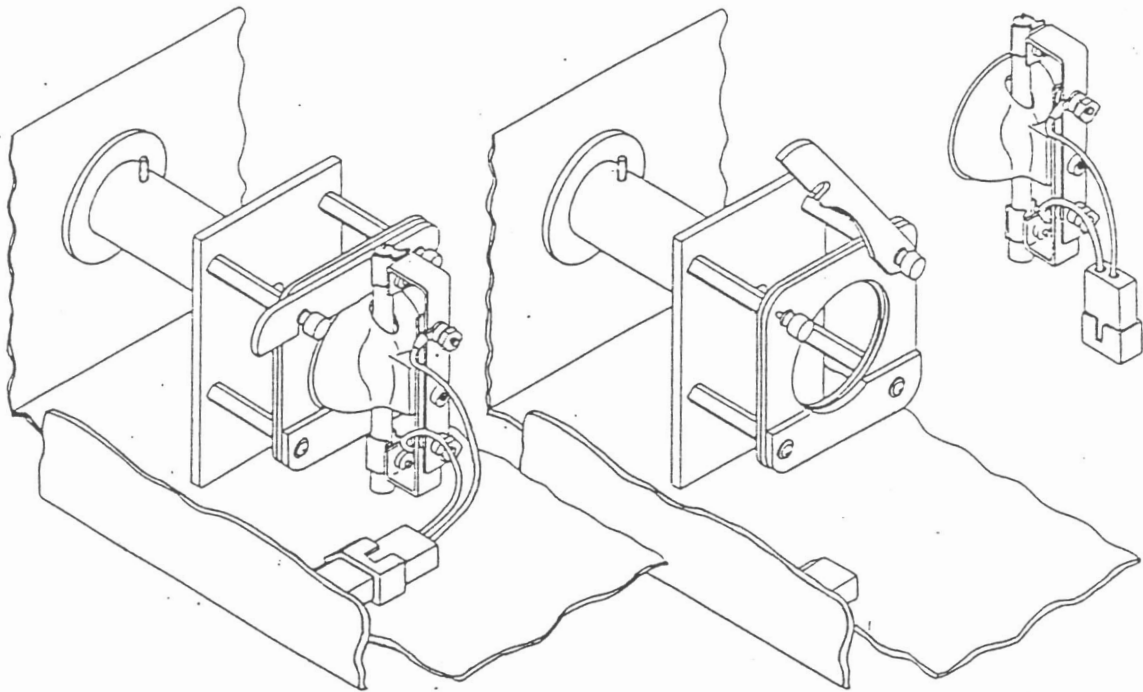

## IV.

### SPECIFICATIONS

Power input: 90-264 VAC, 50/60 Hz, 4 amps.

Ultraviolet output: 2000+ mw/cm<sup>2</sup> at 365 nm as measured with OAI Model 306 radiometer.

Power Supply: 100 Watt solid state, autoranging.

Lamp: 100 Watt short arc mercury, prefocused in reflector.  
Lamp mounted vertically in reflector for longer life and reliable ignition. Quick change lamp - reflector assembly.

Reflector: Elliptical, glass with dichroic coating to reflect UV while transmitting IR.

Lightguide: 5mm x 1000mm liquid lightguide.

Cooling: Filtered dual fan arrangement, one thermally controlled fan to maintain proper lamp temperature regardless of ambient temperature.

Hourmeter: Digital LCD, resettable

## V.

### MAINTENANCE

The Cure Spot HO was designed to operate with minimum maintenance. Follow the schedule below to keep the system in peak operating condition:

- Clean or replace fan filters every 4 months or as required. Wash with warm water and detergent.
- Clean lightguide end monthly or as required. Use isopropyl alcohol and a clean cloth, remove heavy coatings of cured adhesive with a razor blade then clean with alcohol. Cured material on end of lightguide can reduce UV output by as much as 50%.
- Replace lamp-reflector assembly every 800 hours or as required to maintain adequate intensity for curing process. See operation section for instruction on replacing lamp-reflector.
- Inspect IR filter by looking into lightguide socket, be sure system is off and unplugged. Replace IR filter if cracked.

**NEVER ATTEMPT ANY REPAIRS OR MAINTENANCE UNLESS UNIT IS OFF AND UNPLUGGED**

## Va.

### SPARE PARTS

5170 UV Spectacles

\*5069 Lamp-Reflector Assembly

\*5323 Fuse, 3 amp slo blo

5050 Power Switch

5034 Fan Filter Guard Assembly

5267 IR Filter

5071 5mm x 1000mm Lightguide

5246 Filter Assembly, Lightguide

5028 Footswitch

**\*Recommended spare part**

# VI.

## TROUBLESHOOTING

**LAMP DOES NOT LIGHT, POWER SWITCH DOES NOT ILLUMINATE, FANS DO NOT START:**

- Check that power cord is plugged in
- Check fuse in plug receptacle
- Check that cover is properly seated

**LAMP DOES NOT LIGHT, POWER SWITCH ILLUMINATES, FANS START:**

- Check that lamp wires are plugged in
- Lamp at end of life

**UV OUTPUT LOW (READING FROM RADIOMETER):**

- Lamp aged or defective
- Lightguide aged or kinked
- IR filter cracked

**ADHESIVE DOES NOT CURE COMPLETELY:**

- UV output low (see above)
- Adhesive does not cure with long wave UV light
- Adhesive or coating defective

## **VII.**

### Warranty

UV process Supply, Inc. warrants that this equipment will perform in accordance with the performance specifications set forth in the specification section of this manual.

UV Process Supply, Inc. will repair or replace any defective part or parts at no extra charge, excluding lamps, for a period of one year from the date of purchase.

UV Process Supply, Inc. must perform any repairs or modifications needed during the warranty period for the warranty to be valid.

The lamp is warranted for 500 hours for failure to ignite. The lamp is also warranted to produce 60% of initial UV output at 500 hours.

## **VIII.**

### Radiometer

A radiometer is a tool used to measure the out put intensity of a light source. The intensity values listed in this manual were measured with a M007-041 spot cure meter. The intensity reading taken a different type of radiometer should not be compared directly with the values in this manual.

Radiometers from two different manufacturers can give readings that vary by more than 100%. Other radiometers can be used to track lamp life and to determine acceptable intensities to ensure full cure within the curing process time frame.

We recommend the M007-041 because of its consistent, accurate measurement for these types of light sources.

## **IX.**

### UV SAFETY

The cure Spot HO is very safe to use if operated properly. The guidelines below should be followed closely to ensure protection from the UV light.

- 1. UV Protective glasses with side shield must be worn at all times.**
- 2. Never operate the system without the light guide Retaining screw tightened in place.**
- 3. Never direct the light at any body part.**

**Warning: UV ENERGY IS TRANSMITTED FROM THE END OF THE LIGHT GUIDE. PROTECTIVE EYEWEAREQUIPPED WITH SIDE SHIELDS MUST BE WORN TO MEET THE ANSI-Z80.3 CERIFICATION**

All UV safety is the responsibility of the user, especially when operating the system in a non-standard configuration.

**When in doubt about UV safety please call UV Process Supply, Inc. before proceeding 800-621-1296**