

HOW TO BUILD A UV CURING SYSTEM

An introduction to easy, cost-effective integration

UVPS[®]
UV PROCESS SUPPLY, INC.

UV PROCESS SUPPLY, INC. • 1229 W. Cortland Street • Chicago, IL 60614 USA
1-800-621-1296 • 773-248-0099 • Fax: 1-800-99FAXUV • 773-880-6647 • info@uvps.com
W W W . U V P R O C E S S . C O M

Table of Contents

I.	Important Safety Information	<i>page 3</i>
II.	Introduction	<i>page 4</i>
III.	The Irradiator	
	<i>Irradiator Mounting</i>	<i>page 5</i>
	<i>Reflector Schematics</i>	<i>pages 6-7</i>
	<i>Irradiator Cooling</i>	<i>page 8</i>
	<i>Product Cooling</i>	<i>page 9</i>
	<i>Irradiator Shielding</i>	<i>page 9</i>
	<i>Irradiator Wiring</i>	<i>page 10</i>
	<i>Thermal Control Wiring</i>	<i>page 11</i>
	<i>Lamp mounting</i>	<i>page 11</i>
	<i>Lamp Installation</i>	<i>page 12</i>
IV.	Power Supply and Electrical Controls	
	<i>Electrical/Star-up</i>	<i>page 14</i>
	<i>Power Supply Controls</i>	<i>page 14</i>
V.	Maintenance	
	<i>Cleaning Your Irradiator</i>	<i>page 15</i>
	<i>Cleaning the Lamp & Reflector</i>	<i>page 15</i>
	<i>Changing Reflectors</i>	<i>page 16</i>
	<i>Shutter Mechanisms</i>	<i>page 16</i>
VI.	Troubleshooting	<i>page 17</i>
VII.	Wiring Instructions	<i>page 18</i>
VIII.	CFM Requirements	<i>page 19</i>
IX.	Components List	<i>page 20</i>
X.	Order Forms	<i>page 24</i>
XI.	Rental Program	<i>page 27</i>

IMPORTANT SAFETY INFORMATION - PLEASE READ

Before installing or operating any UV curing system, there are several safety precautions which must be executed to ensure safe installation and operation. While common sense is your best defense, always properly shield your employees from direct and reflected light emitted from the UV lamp.

- High intensity, medium pressure, mercury vapor lamps can generate extreme heat and corrosive temperatures. Keep flammable materials a minimum of three feet from any operating equipment.
- UV radiation can cause severe burns to eye and skin. Use protective materials (goggles, glasses), filter screens and curtains to ensure personnel safety.
- In order to help prevent costly downtime and to ensure maximum UV output, practice regular maintenance to ensure proper operation of your curing equipment. This includes the regular lamp and reflector cleaning procedures outlined in this booklet.
- Turn off the power supply at its source before installing a UV curing system, or before performing any maintenance work. **ALLOW TIME FOR CAPACITORS TO DISCHARGE BEFORE WORKING ON ANY POWER SUPPLY. DO NOT TOUCH EXPOSED POSITIVE OR NEGATIVE INTERFACE LEADS WHEN INSTALLING THIS DEVICE.**
- Service or installation work that includes integrating electrical components should be performed by a certified electrician. Never alter the wiring of any purchased equipment. If changes are made, such alterations may damage the equipment, cause injury or death. At the very least, such alterations may void your equipment's warranty.
- When operating a UV curing system, air flow in and around the irradiator (lamp housing) must remain unobstructed.
- User must erect appropriate shielding around the irradiator to protect employees against UV radiation exposure.
- Heat generated from the lamp must be effectively evacuated from within the lamp housing. We recommend a minimum of 10 CFM of air flow within the lamp housing per 100 watts/inch energy supplied to the UV lamp.

IMPORTANT NOTE: Excessive cooling will diminish lamp operating voltage and effectiveness. Inadequate cooling may cause damage to system components. If the shutter is activated (closed), switch lamp power to low (standby) power. Failure to do so will cause the lamp to overheat, and may cause electrical component (fans, wiring, etc.) failure.

AN INTRODUCTION

“UV Curing” is a photochemical process by which monomers undergo curing (polymerization or cross-linking) upon exposure to ultraviolet radiation. A specially-formulated monomer will polymerize when exposed to ultraviolet radiation. This UV “curable” monomer includes a sensitizer which absorbs UV energy and initiates a polymerizing reaction in the monomer.

The rate or speed of curing will depend on the following factors:

The chemical compound

Each monomer will cure at a different rate, depending on its composition and the type and amount of sensitizer, pigment or filling material used. In formulating the UV curable compound, the manufacturer has to consider the physical properties of the finished product as well as curing speed. Therefore, the compound which cures faster is not necessarily “better”.

The thickness of coating

A thick layer of material requires longer exposure to UV than a thinner one. The relation, however, is not directly proportional. The amount of UV energy inside a layer of coating decreases exponentially with depth. If 90% of the UV energy is absorbed in the top 1 mil, then 90% of the remainder, or 9% of the initial amount, will be absorbed in the second 1 mil. In order to bring the level of energy in that second 1 mil to an equivalent amount, it would be necessary to increase the initial radiation ten times. In that case, a two-fold increase in coating thickness would require a ten-fold increase in UV intensity.

The amount of UV intensity per unit surface

Up to a certain point the curing rate will increase with the amount of UV energy per unit surface. This increase is not linear. In fact, the curing rate of most monomers, in the presence of air, rises much faster than the intensity of UV energy. If the amount of UV energy per unit surface is doubled, the curing speed may be tripled, quadrupled, or even accelerated ten-fold. The result of this relation between curing rate and UV intensity is that two UV lamps of a certain power will not affect as fast a cure as the one lamp having twice the power. A more powerful lamp would double the amount of energy falling on the surface, while the curing speed would more than double. UV cure lamps, therefore, should have the highest power-to-size ratio attainable without sacrificing lifetime

or reliability. This non-linear relation between cure rate and UV energy dictates the design of the reflector to be used in conjunction with the UV lamp. A reflector that concentrates UV energy on a small surface will provide faster curing than a reflector giving a uniform distribution of UV over a larger surface.

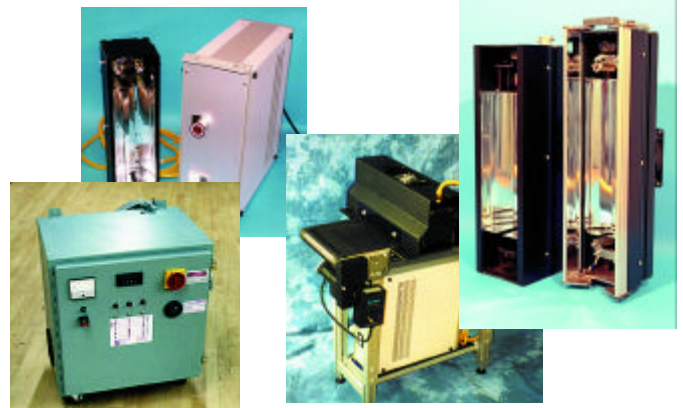

The UV spectrum emitted by the source

Not all UV sensitizers require the same range of UV wavelengths for proper reaction. The sensitizers should absorb UV in a range which is not absorbed by the monomer or the pigment. The wavelength emitted by the UV source should coincide with the wavelength absorbed by the sensitizer. Since medium-pressure mercury vapor lamps emit a wide range of UV (180-400nm), they are suitable for all UV cure applications. Commercial applications include curing of printing inks, wood coatings, particleboard fillers, metal coatings, adhesives, fiber optics and polystyrene.

Among the many advantages of the ultraviolet process and apparatus are:

- Produce high quality identical products.
- Achieve outstanding product uniformity.
- Easy to operate
- Convenient to use
- Economical
- Efficient
- Effective

This booklet will discuss the primary concerns for integrating UV curing into your production line:

- Irradiator
- Power Supply
- Maintenance
- Troubleshooting
- Safety Precautions
- Technical Specifications

THE IRRADIATOR

Specially designed irradiators in arc lengths of 2 to 77" are available from UV Process Supply. These irradiators, when used with the recommended cooling, maintain optimum operating temperatures on the lamp envelope, end seals and lamp end holders.

The irradiator, which is also known as the lamp housing/reflector assembly, has three critical functions:

1. To support the lamp above the substrate
2. To reflect the UV energy in a pattern best suited for fast curing; and
3. To facilitate cooling of lamp seals and sockets (but not the lamp itself)

UV Process Supply's Lighthouse™ irradiators consist of an aluminum housing which contains a linear reflector with an elliptical cross section and holders for securing lamps with metal or ceramic end fittings. When selecting an arc length (or effective curing width), choose a size at least 3 to 4" larger than the maximum width of the area to be cured. This allows for any variation in substrate placement on conveyerized systems, and for compensating for less curing energy as lamp ends deteriorate.

The lamp is positioned in relation to the reflector so that the maximum amount of energy emitted from the lamp is gathered and focused in one focal point. This focused light band causes most UV coatings to cure at optimum speeds. The focal point also defines the distance the irradiator is to be mounted above the curing surface so it receives the maximum amount of curing energy. This

focal point is a highly concentrated band of UV energy approximately 3/8" wide and equal in length to the arc gap of the lamp.

In order that the lamp operates properly, it must operate at a rather high temperature, between 600-800°C on the quartz envelope. However, the end seals must be kept cool, approximately 250-300°C maximum. If the seals exceed this temperature range, it could cause the molybdenum foils to oxidize and the seals to fracture.

As the high operating temperature would tarnish and warp an ordinary fixture, the aluminum housing is designed to form an air cooling plenum. This serves to cool the seals and irradiator hardware, including the reflector, but not the lamp. [Due to these performance standards, the reflector is made of a specialized, highly polished aluminum which features high UV reflectivity (about 90%) and exceptional resistance to temperature, tarnishing and corrosion.] Yet, if the lamp ends blacken, crack and then fail, this is generally due to over-cooling. Therefore, air flow must be carefully controlled.

Irradiator Mounting

To ensure proper focus of the irradiator in relation to the product surface, the proper focal distance of the irradiator must be known. By understanding the focus point from the center of the lamp, you will know exactly at what distance the irradiator can be mounted above the substrate to deliver most effective cure. As Lighthouse™ irradiators are designed with the lamp in focus in relation to the reflector, this permits energy focus to be optimized, unlike other systems.

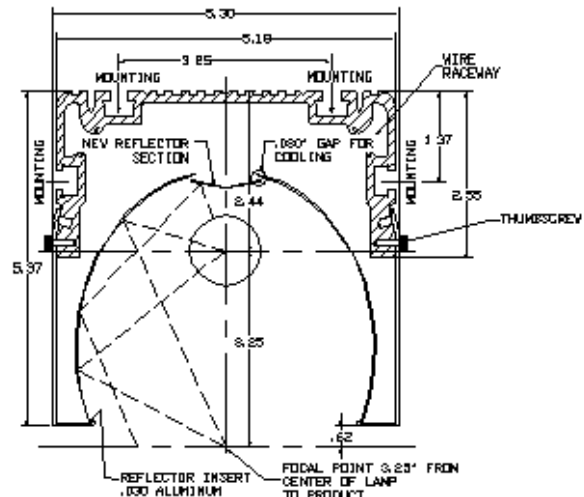
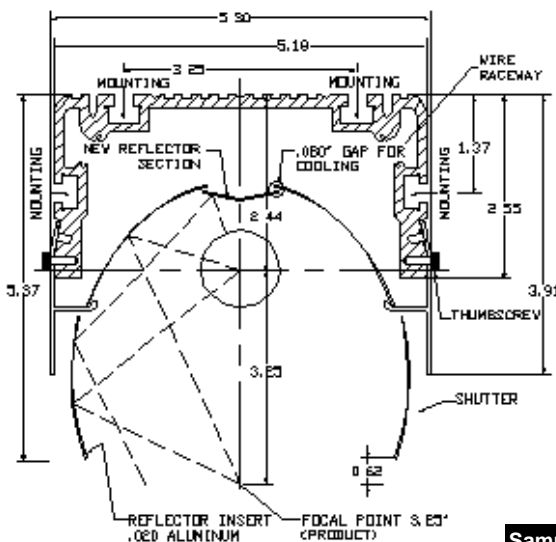

Sample cross sections of the Lighthouse™ profile. See following pages for full view.

LIGHTHOUSE™ 3/4 ELLIPTICAL REFLECTOR w/SHUTTER

Irradiator Profile

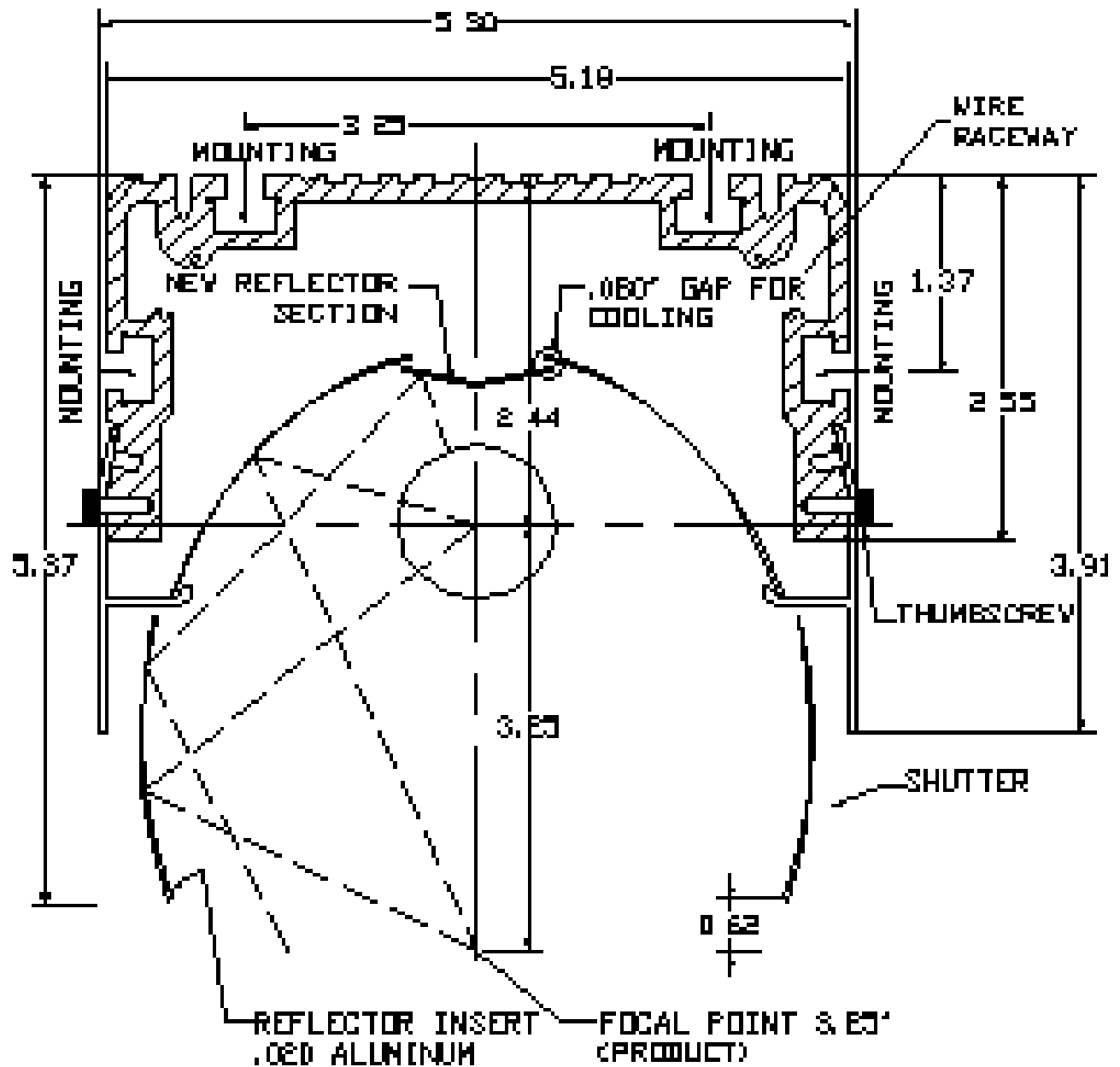



The Lighthouse™ is equipped with high velocity muffin fans to effectively cool irradiator components, including the reflector and lamp ends. The system's plenum design prevents air from lowering lamp temperature to maintain consistent energy output.

The Con-Trol-Cure Lighthouse™ features a 3/4 elliptical reflector which should be mounted 3 1/4" from the 1/8" (3 mm) Focus Reference Hole (or center of the lamp) to the substrate surface. This would provide 5/8" clearance from the base of the housing (open shutter for shuttered unit) to the top of the substrate.

Important Note: When mounting any UV lamp housing, you must compensate for thermal expansion. A 38" lamp will expand approximately 1/16" during an operation, and a 77" irradiator can expand 1/8" or more. Therefore, allowances must be made to compensate for this fluctuating position.

Irradiator Cooling

A UV lamp generates such intense heat that it can quickly melt an aluminum reflector and damage other internal irradiator components if no cooling is provided. Yet, as cooling the lamp will cause the mercury to condense and lower energy output, maintaining lamp temperature is critical to efficient lamp performance. Therefore, the irradiator must be designed to effectively cool these components without affecting lamp temperature.

With the Lighthouse™, cooling is accomplished by a series of fans positioned over the reflector and secured to the top of the housing. Lighthouse's 3-part reflector, which includes a V-shaped reflector positioned directly above the lamp, permits air flow over both sides of the reflector but deflects air away from the lamp. As the fans

blow air down around both sides of the reflector, it is deflected away from the lamp to maximize lamp efficiency. Channeled air ducts at the base of the housing permit heated air to flow-through. Be sure never to block these ducts.

The Lighthouse™ also employs a ribbed reflector support structure in place of the solid aluminum extrusion support used within most irradiators. This system permits unobstructed, more efficient use of air flow. Lighthouse's V-shaped reflector strip also deflects light from behind the lamp to the reflector and away from the quartz envelope to further diminish heat build-up within the housing.

The muffin fans are installed and operated so that air is drawn into the top of the housing and blown down across the substrate. Some systems permit fan-generated air flow to be reversed, allowing the fans to draw air up towards the reflector and lamp. This activity is not advised as redirecting air flow in this manner may ultimately increase lamp or reflector contamination due to out-gassing of some coatings. This may also reduce lamp efficiency as air will be drawn over the quartz envelope, thus reducing lamp temperature.

To accelerate start-up, we recommend keeping the fans off when initially turning the system on. By generating additional heat around the quartz sleeve as the mercury vaporizes, you can significantly reduce the warm-up

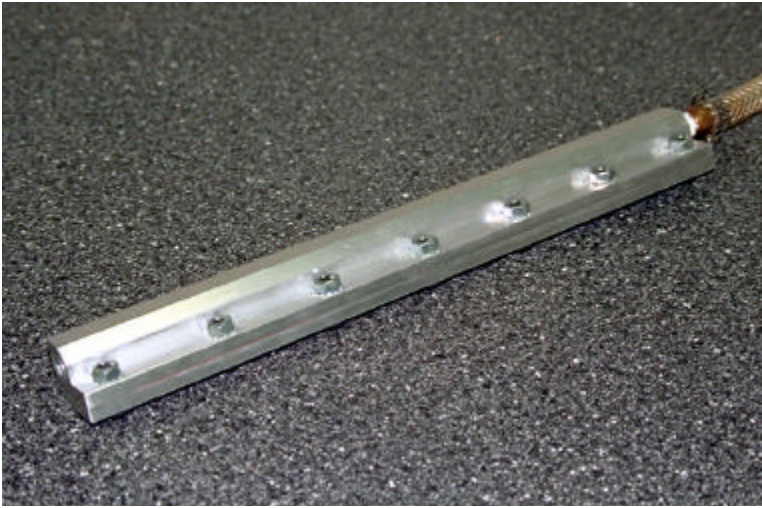

Air knives are just one of many methods used to reduce substrate temperature as the cured material exits the curing chamber. Air knives are narrow profile cooling sources which can be positioned directly at the chamber exit to significantly reduce heat build-up. Studies show substrate heat continues to rise after the material exits the chamber. Therefore, such cooling sources effectively minimize heat build-up before distortion factors can take hold.

period. Caution should be exercised since overheating and meltdown of the reflector can occur if the fans are not activated accordingly. Lighthouse™ power supplies incorporate a timer which activates the fans after a specific amount of time is allowed for start-up.

Consult with your electrician and manufacturer to determine the operating parameters and electrical specifics for integrating such a feature into your curing system.

Product Cooling

Heat generated by the UV lamp can shrink or distort different types of heat sensitive substrates during curing. In order to protect the substrate, some type of cooling mechanism may be required. Before considering product cooling alternatives, though, always keep separate the concepts of product cooling and lamp cooling. Many facilities neglect this matter, and automatically reverse air flow on their system's cooling fans, drawing air up from the substrate. When they begin to experience a significant loss in performance, many times they do not understand how the reversed air flow has changed the performance characteristics of the lamp. Therefore, it is usually recommended to maintain your manufacturer's recommended air flow patterns regarding irradiator cooling, and consider other add-ons or alternatives should product cooling be required.

Air Knives are an example of how an external cooling

source can help prevent product distortion without affecting lamp operation. When attached to the outside of the housing, each Air Knife acts as high velocity air delivery system that effectively cools the substrate as it exits the curing chamber. Con-Trol-Cure Air Knives (6" - #A005-009) (12" - #A005-010) (18" - #A005-011) (24" - #A005-012) (30" - #A005-013) (36" - A005-014) blow a continuous, narrow stream of air over the substrate to dissipate potentially damaging heat build-up.

Some irradiators are or can be equipped with a port located at one end of the irradiator which will accept a flexible duct which can be attached to a high velocity blower. Flexible duct is recommended to allow for the thermal expansion. Cool air should be brought into the irradiator at the wiring end and hot air exhausted through the opposite end. If irradiators are to be placed end-to-end, as required in many wide-web applications, the irradiators should be staggered mounted, and additional cooling will be necessary.

Irradiator Shielding

UV radiation can cause severe burns to eye and skin. Looking directly at an operating UV light, or even at reflected light, should be avoided at all times. Properly shielding the irradiator, wearing UV protective eyewear and clothing around operating UV curing systems, and following general safety practices are your most effective protective measures against over-exposure.

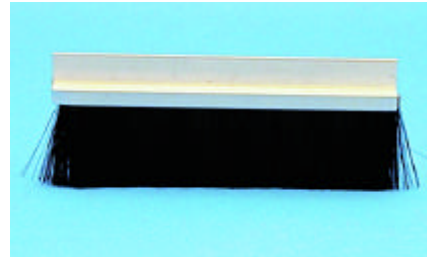
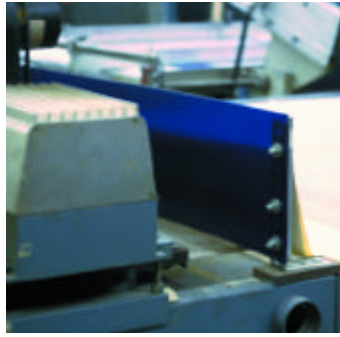
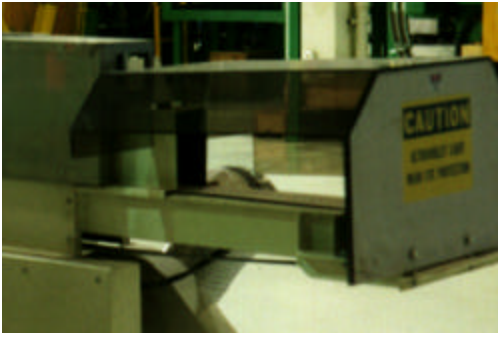

Irradiator shielding techniques include the use of rigid UV filter materials (available in various colors, transparencies and filtering capabilities) and filter curtains.

After mounting your irradiator in-line, it is critical to shield the housing so that light emitted from the lamp does not harm your employees. Typically, the open side of the irradiator (or side which faces the substrate) is positioned above the substrate and allows light to escape into an unprotected workplace. Placing chevrons, transparent UV filter material (Item #F007-002 Clear; #F007-015 Bronze; #F007-022 Blue), UV Viewing Windows (Item #I005-013: 1-3/4 x 3-3/4"; #I005-011: 3-7/8 x 4-3/4") or solid metal guards around these openings should effectively guard against exposure. Whatever guards are installed, the material used should be high temperature resistant, non-reflective, and, if working with a temperature-sensitive application, should permit air to flow through the shields to assist in substrate cooling. Chevrons are a typical choice for these applications.

Important Note: Avoid building shrouds around the complete housing which completely encase the irradiator's cooling mechanisms. If the irradiator's cooling fans are encased, they will not function properly, and may cause the system to overheat. This result may cause lamp failure and reflector meltdown.

Even with the proper shielding in place, OSHA requires employers to make available and require employees to wear suitable eye and face protection where eye injuries may occur. In order to help comply with OSHA require-

ments and to provide safety for your personnel, UV Process Supply offer's an array of UV filtering safety glasses and sheet materials carefully selected for the needs of UV applications.

Irradiator Wiring

IMPORTANT NOTE: Before wiring any irradiator, disconnect power at its source. If the power supply to which the irradiator will be wired has been used recently, allow time (approx. 30 minutes) for the capacitors to discharge stored energy before starting any work.

Connecting the four wires from the irradiator to the power is relatively straightforward. When wiring the Lighthouse™ irradiator to the power supply, use appropriate high voltage and high-temperature, UL-approved wire (#A005-004). As electrical codes vary from region to region, we recommend reviewing those specifications before beginning any installation. We also strongly recommend the use of a certified electrician when installing and/or wiring this unit. Refer to the power supply schematic to ensure proper installation.

The terminal box should always be located away from high heat areas. Lamp wiring should be paired in a separate conduit from the terminal, or breaker, box to the power supply. Proper labeling should also be posted (i.e. "WARNING: HIGH VOLTAGE").

OSHA regulations mandate that employers provide employees who work in the vicinity of operating UV curing systems be provided UV filtering safety glasses to protect against eye damage. UV Process Supply offers a complete range of glasses, goggles and safety shields to protect employees from such hazardous exposure.



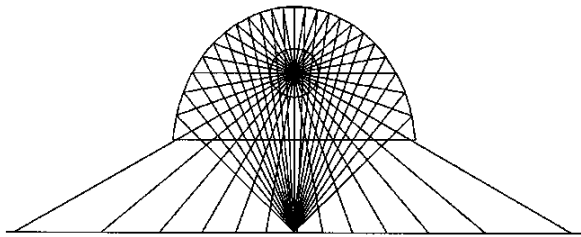

Properly positioned, focused lamp

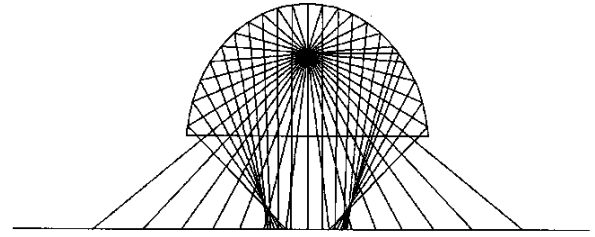

Lamp positioned 1/4" too high

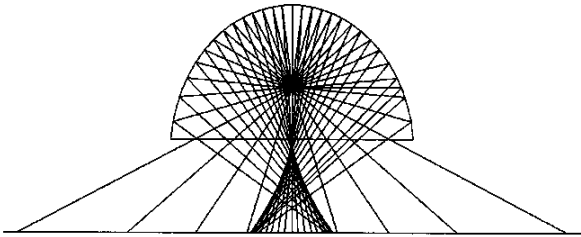

Lamp positioned 1/4" too low

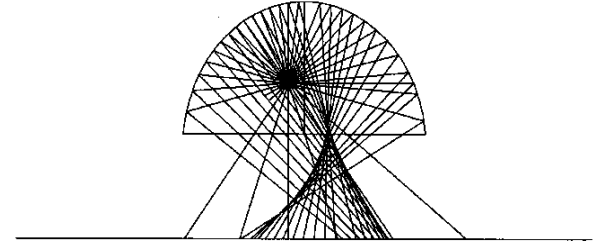

Lamp positioned 1/4" too far left

Integrate the cooling fans by connecting two high temperature, UL-approved 20 gauge wires (# A005-003) to the terminal block (refer to schematic diagram). See fan voltage rating for power source and schematic diagram for appropriate wiring connections.

Electrical connections and wires should be examined on regular basis. UV curing environments produce tremendous amounts of heat, UV light and (usually) ozone. Exposure to harsh UV can deteriorate the integrity of internal components. However, parts of the Lighthouse™ irradiator (thin reflector sheets, gap for cooling and lamp housing fans) are designed to withstand such effects.

Thermal Control Wiring

The Lighthouse™ irradiator can be equipped with an Thermal Control Package for wiring to a Lighthouse™ Power Supply, which includes a therm-safe and cutoff features. These combined features will shutdown the power supply if the irradiator begins to overheat.

For these systems, each muffin fan on the irradiator housing is equipped with a thermostat for monitoring temperature (and, as a result, operation). This feature can prevent damage to your curing system, and will allow you

time to determine the reason for overheating prior to restarting the system. For wiring into the power supply, please check your power supply wiring diagram before initiating any wiring. Be sure to turn power off at its source prior to any maintenance work. UVPS power supplies incorporate a disconnect door switch which shuts power off whenever the door is ajar.

Lamp mounting

Before installing or focusing a lamp, open the door to the power supply, and disconnect the irradiator from the incoming electricity to ensure complete safety.

The reflector is designed to focus all rays from the lamp in front of the reflector opening. Therefore, the exact focal point of the lamp in relation to the reflector needs to be determined to maximize system efficiency and effectiveness. As different lamp ends and lamp diameters can change lamp focus, it is necessary to understand how to to maintain proper focus should your lamp dimensions change. In the end, accurate lamp position insures optimal focus. Lighthouse™ irradiators are manufactured to maintain proper lamp focus, unlike other systems.

As mentioned earlier, with the Lighthouse™ irradiator,

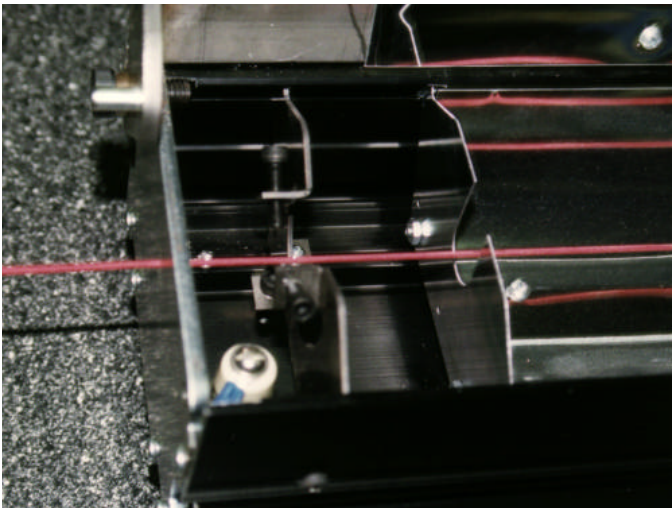

The Lighthouse's Focus Reference Hole offers a quick method for centering different diameter lamps in relation to the irradiator's reflector. The FRH assists you in maintaining optimal energy focus and lamp position regardless of lamp type or size. Adjustable lamp holder positions allow you to quickly reposition lamp height to meet new requirements.

the center of the lamp should be positioned exactly 3.25" from the Focus Reference Hole to the product surface. By using the Focus Reference Hole found on each end plate, the user can adjust the position of the lamp on the universal lamp holder. Centering the lamp's focus is found to be more critical than we expected. Mounting the lamp 1/4" upwards, downwards or to the left (for systems which offer left-to-right adjustments) will greatly affect the efficiency and intensity of the lamp's ultraviolet energy.

Lamp Installation

With the housing mounted and focused, loosen and remove one nut per side and swing the lock-down clamp away from the reflector. Place the lamp's ceramic or metal ends into the v-notched universal holders, and swing the lock-down back into place. Lightly tighten the wing-nut so that the lamp "floats" in the holder. *Important Note:* The holders must permit some lamp movement to

compensate for thermal expansion. If the holders are over-tightened, and cannot compensate for the lamp's expansion during operation, the encasement may crack. Therefore, ensure some play remains between the brass nuts which hold the lamp holders when installing a new lamp. Lighthouse's lamp end holders allow you to compensate for thermal expansion; check the specifications of other manufactured systems to ensure such adjustment is possible.

When installing any lamp, always wear cotton inspection gloves to protect against touching the quartz envelope. Always remember to clean the lamp and reflector after install to remove any foreign matter. Do not allow fingers or hands to touch the quartz envelop after cleaning or during lamp mounting. Dirt and foreign particles can reduce a lamp's effectiveness, can cause a lamp to fail prematurely, or can obstruct UV light.

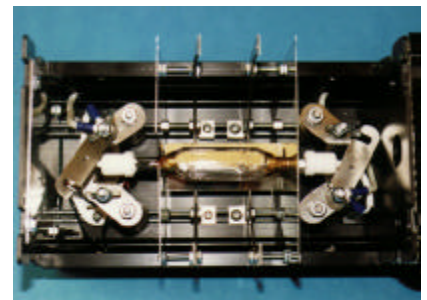
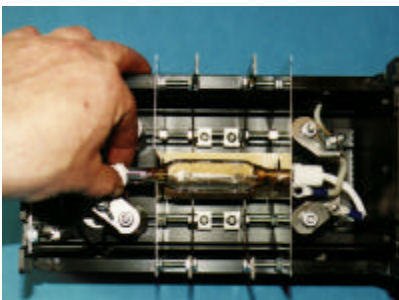

Lighthouse's universal lamp holders accept any type of lamp end fitting, metal or ceramic. Both holders are height adjustable, and, when used in conjunction with the Focus Reference Hole, allow to you properly focus lamp's of different diameters and sizes. When installing any lamp, do not overtighten the lamp end fittings. Allow the lamp to "float" to compensate for thermal expansion.

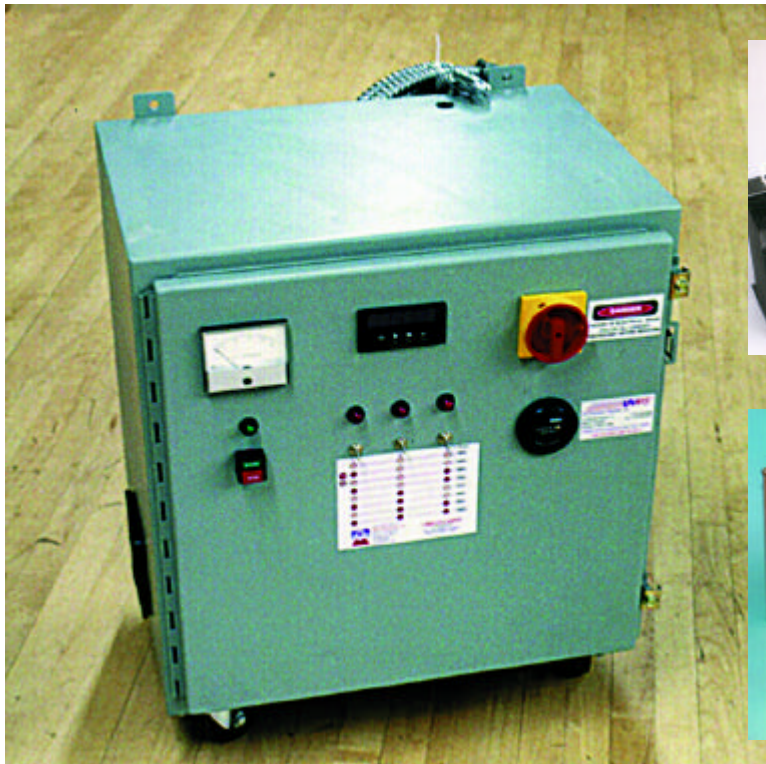

POWER SUPPLY AND ELECTRICAL CONTROLS

A custom electrical system must be employed for proper ignition, warm-up and operation of UV-emitting curing lamps. This system must be specifically matched to the lamp's arc length and electrical requirements (watts/linear inch) as the lamp requires high voltage to initiate the arc and lower voltage to sustain it while it is operating. The electrical system must also match the type of lamp to be ignited. A standard mercury vapor lamp, for instance, requires a different electrical system than a metal halide (iron or gallium doped) lamp.

Although the lamp receives a "spike" to vaporize the mercury when it is initially turned on, a current limiting device is necessary to prevent excessive current flow throughout the "warm-up" period as the lamp attempts to draw as much energy as possible to build resistance within the quartz envelope.

To ensure constant curing speeds during operation, the electrical system must be power regulated or "stabilized". A stabilized system supplies constant power to the lamp even with variations in the line voltage. During the starting period, lamp voltage will be approximately 30% higher than the operating current. (Determine circuit breaker amperage required with this formula: Arc length

x watts per inch / voltage (240 or 480) x 1.15 = Circuit breaker amperage required.)

The encased power supplies designed and manufactured for UV Process Supply consist of a transformer and a combination of 3- or 8-level variable switching. In typical UV curing operations, one ballast (or stabilizer) is required and designed to operate one UV-emitting lamp (mercury standard; iron, gallium, etc., by special order) of a specific arc length. These ballasts supply constant power to the lamp, and their power variation will not exceed +/-3% even with line voltage fluctuations of up to +/-10%. As supplied, the ballasts will operate the lamps at full power. However, operation at intermittent power levels is possible by use of a capacitor switching network. Ballasts are available in a variety of input voltages and for operation on either 50 or 60hz.

Encased power supplies are available for operation with the standard line of UV Process Supply 300 and 400 watts per linear inch lamps, with 600 and 750 WPI systems available by special order. These types are encased in a steel housing and include switches and controls for all lamp functions. Unencased ballasts and capacitors are also available for users supplying all wiring and switching control functions, or as a replacement ballast. Either type may be wired to provide lamp operation at reduced power.

Electrical/Start-up

With the lamp and reflector secured in place, and all shields locked down, you are ready to power up the unit. With the reflector and lamp shielded against harmful exposure, turn the power supply ON.

Refer to your lamp manufacturer's specifications indicating the length of time required for the lamp to reach stabilization (may vary from 20 seconds to 5 minutes). After the warm-up period is complete, the lamp is ready to use for your curing application.

Important Note: Remember to wear UV protective eyewear and clothing when operating this system. Also protect against heat exposure as the unit may exceed 125°F.

Power Supply Controls

Main Power ON/OFF:

Shuts off electrical connected to power supply. Includes safety lock which prevents power supply cabinet door from being opened while power is ON.

Start/Stop w/Indicator Light:

Two-position push-button switches power ON (Start/green) or OFF (Stop/red) to end source (irradiator). When red indicator light is ON, power is ON to the irradiator. Power must be turned ON at the Main Power ON/OFF switch for this secondary switch to work.

Ammeter:

Meter indicates real-time amperage draw being used by the power supply (on most manufacturer's equipment).

Lamp Voltage Interface (for UV Process Supply systems only):

LED displays numerical level of electrical current. Interface permits input of high and low presets to warn user if lamp is drawing energy in excess or below levels required to produce the desired cure.

[The Lamp Voltage Interface is integrated parallel to your curing equipment's power supply and irradiator to provide continuous feedback of voltage level during operation. Interfaced with a high impedance panel-mount volt meter, the LVI provides a numerical power reading of lamp energy draw. The operator can use this numerical value to determine when a lamp stabilizes and is ready for use. This numerical value is critical in establishing an initial baseline after installing a new lamp.

As the lamp degrades over time, or if air flow (cooling) within the housing inadvertently lowers lamp temperature, the lamp will draw less energy. As a result, the LVI's numerical reading will be less than its initial baseline. This indicates the lamp is drawing less power and may be performing at less than peak efficiency.

By noting this change in numerical values, you can quickly cross-check this variance through physical cure evaluation before under-cured product is generated. If the tested product fails to cure at this numerical value, you can eliminate the inefficiency by cleaning or changing the lamp, by cleaning or changing the reflector, by increasing power, or by changing air flow characteristics.]

Hour Meter:

Counter displays number of hours a system has been operating. It is recommended that the operator note the present hour meter value when changing bulbs to help measure new lamp life.

Power Level Settings:

8 different power level settings (3 settings on Basic power supplies) to suit your specific application. Choose from 40 to 100% maximum power level. To adjust power level, position the three power toggle switches as described on the Main Control Panel to achieve the require setting.

CONTROL PANEL

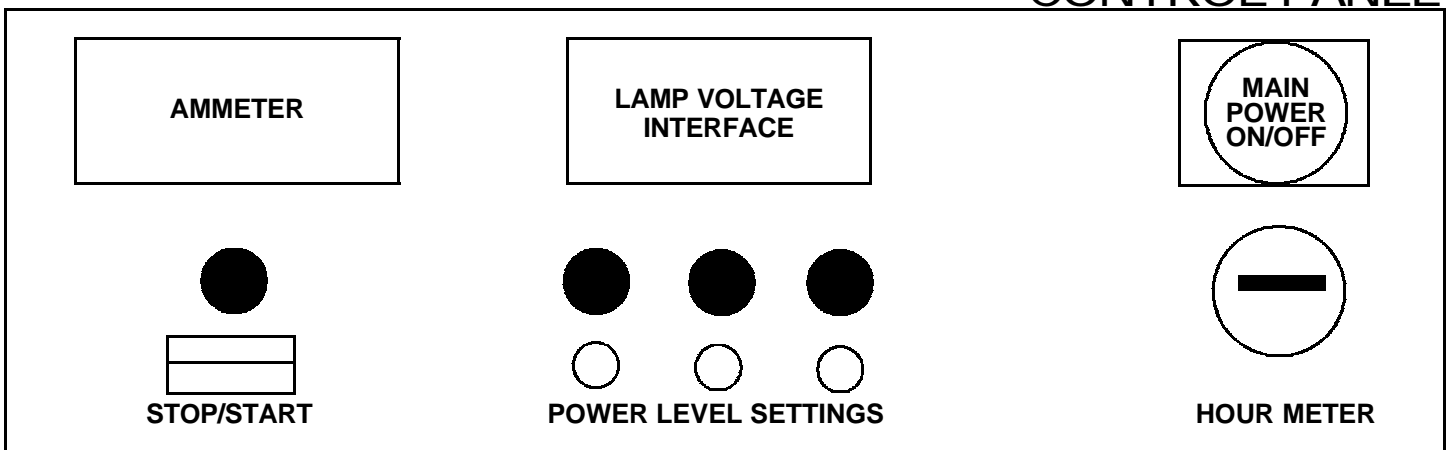



When handling mercury vapor and other UV curing lamps, wear cotton inspection gloves to prevent fingerprints from marring the quartz envelope. UV Process Supply offers a special lamp and reflector cleaning solution which effectively removes foreign matter from the quartz envelope without residue to maintain maximum energy efficiency.

MAINTENANCE

Cleaning your irradiator

Dust, dirt and fingerprints on the lamp should be removed prior to installation to assure that such contaminants do not damage the quartz envelope. As the lamp's intense heat can cause such particulate to fuse to the quartz envelope, dirt, dust and fingerprints on the lamp and reflector will absorb the UV energy and turn emitted energy into unwanted infrared. This can dramatically reduce irradiator operating efficiency and effectively reduce lamp life. In addition, an accumulation of such deposits over time will gradually reduce uniform delivery of light, reduce UV intensity and lessen cure efficiency. Therefore, regular lamp and reflector cleaning can maintain consistent operating performance, and extend the life span of your irradiator's consumable components.

We highly recommend that you maintain a log to schedule future maintenance procedures. Such scheduling can prevent problems which lead to costly downtime, and ensure maximum UV output and operating efficiency.

We also recommend maintaining an inventory of spare replacement lamps and reflectors in case of sudden failure. UV Process Supply offers a full range of replace-

ment lamps, reflectors and parts to address these concerns. UVPS also offers a special lamp stocking program to ensure your lamp is available whenever you need it.

Cleaning the lamp & reflector

UV Process Supply's Lamp and Reflector Cleaning Solution (Part # - A002-019) will prevent a thin film of foreign matter from accumulating on the lamp. Use this cleaning solution to clean lamps and reflectors so no organic materials can affect optimum light transmission.

Dampen a lint-free wiping towel with the lamp cleaning solution. Wipe the UV lamp directly with the dampened cloth. Dry and polish lamp with a clean wiper that contains no chemical binders or any particles that can scratch.

Always wear cotton inspection gloves (Men's - #1004-022) (Ladies' - #1004-031) when handling the UV lamps. Do not allow fingers or hands to touch the lamp body after cleaning or during lamp mounting.

The Con-Trol-Cure UV Lamp and Reflector Maintenance Kit contains everything you need to clean UV lamps and reflectors thoroughly: cleaning solution, soft, lint-free wiping towel and cotton inspection gloves.



When performing scheduled maintenance on your UV production equipment, properly lubricate shutter mechanisms and other moving mechanical components which may be exposed to UV energy with UV Grease. This material is designed to withstand the high temperatures and extended exposure to UV light without breaking down.

To replace reflector material within the Lighthouse™, simply loosen the thumb screws which retain the irradiator's side panels. With the panels removed, reflector material can be simply lifted from the ribbed supports and replaced.

Changing Reflectors

Second only to the lamp itself, the reflector is the most critical component in the irradiator system since it directly affects the amount of UV energy focused on the curing surface. During production, various deposits accumulate on reflector surfaces to greatly lessen cure efficiency. While some systems do not permit reflectors to be exchanged, scheduled cleaning can help maintain consistent performance. To properly clean the reflector, follow the directions outlined above for lamp cleaning. If the reflector is permanently contaminated, pitted, scratched or has lost its reflective quality, it should be replaced if at all possible.

Unlike most other systems, which do not permit easy reflector replacement, UV Process Supply's Lighthouse™ is designed to allow quick reflector replacement. In most operating environments, the operator can change the complete reflector within minutes. This quick-change feature significantly reduces downtime while allows the user to maintain optimum reflectivity and performance at minimal cost. **IMPORTANT NOTE:** Be sure to practice the same safety procedures as when replacing a lamp.

The Lighthouse™ reflector kit consists of a "V" reflector strip, elliptical half sides, and shuttered reflector strips for shuttered units.

Because of the Lighthouse's special design, changing the reflector is simple. Replace the V reflector strip (Shuttered -#U004-006) (Non-shuttered - #U004-007) found on the center of the lamp housing by alternately twisting it behind the hooks of the rib. Make sure the hooks are alternately opposite each other. If the first hook on the first rib is on the right side, the second hook on the second rib must be on the left side of the lamp housing. For replacing the elliptical half-sides, simply loosen the thumb screws which attach the irradiator side

panels. By removing the side panels, the reflector material can be lifted and replaced.

The ends of the UV lamp are critical because as the lamp ages, the lamp emits less energy at the ends than at the center. The Lighthouse's end reflectors (Shuttered - #U004-008) (Non-shuttered -#U004-009) reflect more light at the end of the lamp to improve curing consistency across the lamp's full arc length.

Ultimately, changing reflectors frequently is a cost-effective measure. It also provides the highest level of assurance for effective UV curing. When cleaning reflectors, use same cleaning procedures as cleaning lamps. Never use abrasive cleaning compounds or steel wool for cleaning reflectors. These harsh products will remove its protective finish and reduce the reflector's capability.

SHUTTER MECHANISMS

Lighthouse™ shuttered irradiators, typically used in web applications, protect the substrate from excessive heat damage. A solenoid switch is required to integrate shutter motion with equipment operation to ensure the shutters activate when the web is stopped. A relay is also required to lower lamp output/temperature (high to low power) when production stops to protect the reflector and substrate from damage.

Shutter mechanisms and grippers should be examined periodically for proper operation. Replacements for all wearable parts should be kept in stock to avoid costly downtime and delays. Treat mechanical components with UV Grease (#U000-000), which contains rust and oxidation inhibitors, lubricity additives and synthetic oil base. It is specifically designed not to breakdown upon exposure to UV energy, and is suitable for application onto components such as grippers or shutters.

